



JLM 2.14

MARINE DIESEL ENGINE

JLM Marine Power marine diesel engines is a new generation of engines with a PERKINS engine as its base. The base engine is constructed for industrial application and marinization for toughest conditions, which ensures reliability and long life. Through smart design and excellent quality of construction we achieved easy access to engine and economical maintenance. Thanks to low weight, minimal noise and vibration, and its compact size, it is ideal for use on sailboats, recreational, work and fishing boats. Due to the new injection system, reduced fuel consumption has been achieved. This engine meets stringent world-law emission specifications for exhaust gasses (EU Stage IIIB and U.S. EPA Tier 4).



**JLM
WARRANTY
★ ★
2
YEARS**

JLM 2.14

"JLM marine power": standard 2 years warranty proves our quality, durability and reliability

SPECIFICATIONS

Engine type:	JLM 2.14
Base engine:	PERKINS 402D-05
Output power at crankshaft (ISO/TR 14396):	10,2 kW / 13,7 HP
Number of cylinders:	2 (in line)
Displacement :	507 ccm
Cycle:	4 stroke
Bore x stroke:	67 x 72 mm
Cooling system:	Closed system with freshwater and heat exchanger
Max. engine speed:	3600 rpm
Compression ratio:	23.5:1
Combustion system:	Indirect injection
Aspiration:	Naturally aspirated
Marine gear box:	KBS 080 mechanical, drop center
Weight with gear box:	104 kg
Exhaust pipe diameter:	Ø 48.3 mm
Sea suction diameter:	Ø 17 mm
Fuel connection diameter:	Ø 8 mm
Alternator:	12V 40A
Exhaust emissions:	US-EPA Stage III&Tier 4b

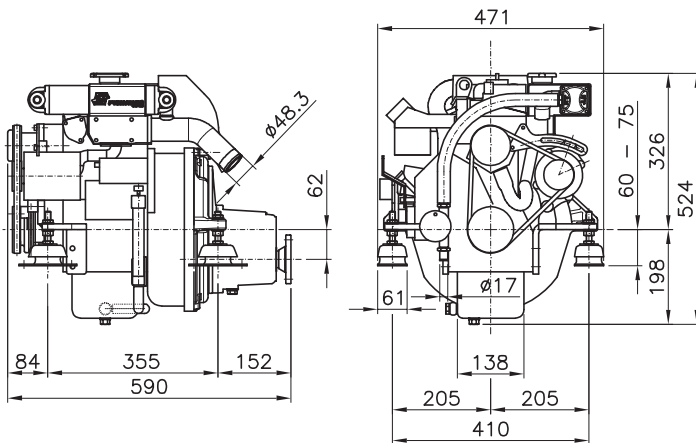

EQUIPMENT

STANDARD EQUIPMENT:

- **marine gear box KBS 080** (ratio 1:1,96 ; 1:2,72)
- **CPS analog instrument panel with extended cable** (revolution counter, digital counter of working hours, light and sound alarm signal for oil pressure and water temperature, contact lock with key, heater indicator, five meters of cable)
- **flexible engine mounts**
- **manual pump for oil exchange**
- **marine gear box cable bracket and throttle cable bracket with attachments**
- **extra pulley (for example hydraulic operated or cooling compressor etc...)**
- **alternator: 12V 40A**
- **operation and maintenance manual**

OPTIONAL EQUIPMENT:

- **complete shafting**
- **propeller**
- **single lever control with cable**
- **flexible exhaust hose**
- **water lock with silencer for exhaust gas**
- **fuel tank**
- **non-standard instrument panel**

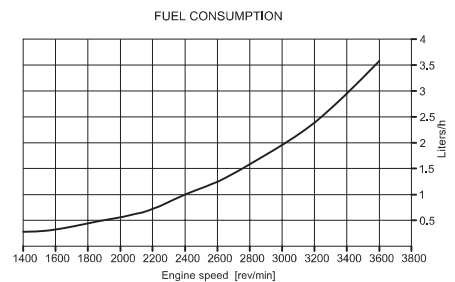
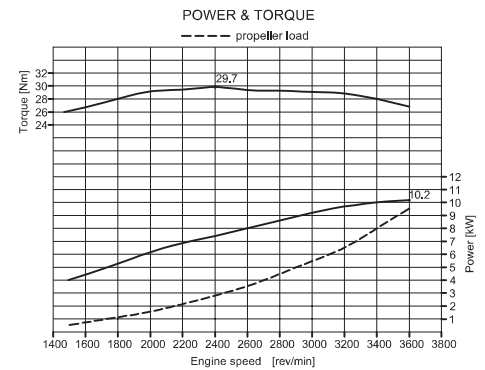

AUTHORIZED DEALER



JLM 2.14

JLM PERKOVIĆ d.o.o. / Put Luskino b.b. / 51211 Matulji / CROATIA / T. +385 (0)51 275-121 / F +385 (0)51 275-122 / perkovic@jlm-perkovic.hr

www.jlm-perkovic.hr